



FOUR DEAD

Official Newsletter of the Idaho Horseshoe Pitcher's Association



Volume XXV, #1

Spring 2014

President's Message



Well, it is time again to dust off your shoes and get back out and start throwing! Please print the 2014 schedule, mark the dates that you plan to attend the tournaments, and make sure you register by the appropriate times.

Please send your dues to Jerry Smith or your local club secretary and register for this season. The dues and fees have stayed the same--NHPA: \$17/Adults and \$5/Juniors; Idaho: \$8/Adults and Juniors are free for Idaho. (Total: \$25/Adults, \$8/Juniors)

I would like to stress that we all need to be working on new members. Please talk to someone every day about horseshoe pitching and the fun that we all have being together. Promote this as an activity that you are proud to be associated with, and by talking about it will help show how much you enjoy it.

I have Idaho pins available for purchase if you need any. They are \$2 each; this is a fundraiser for the Gate City Horseshoe Club.

I think at the beginning of each season we need to set goals as an association, as a club, and as an individual of what we would like to accomplish every year. My first goal this year is to bring one new member into our club; my second goal is to bring my ringer percentage up to 30%. I know it will take some work and dedication on my part to accomplish both of these goals, but I am dedicated to help our association grow and showcase our sport to all I come in contact with. So please put some goals on paper so you can post it, see it every day, keep them on your mind, and work on them.

If you have any suggestions, please call or email me or any of the officers and let's discuss what suggestions you have.

Thanks for all you do to promote horseshoe pitching, and I hope to see you at some tournaments this summer!

Brian J Poole, ISHPA President
208-237-3459
bjpoole3564@gmail.com



Secretary Sez



This issue includes the 2014 schedule and is being sent to all by snail mail so that everyone has a "tear-away" 2014 schedule. The e-version will also be sent out so that you will have the enhanced version electronically. Remember that you must have at least four

tournaments pitched since the 2013 entry deadline to enter the World Tournament.

The 2013 entry deadline was around May 15, 2013. The Charter dues remain at \$25.00 and can be sent in at any time.

The Idaho State Tournament will be on August 23 and 24 in Coeur d'Alene. Glen Wessel is the local (CDA) contact and can be reached at 208-691-0784. Make your plans early in order to get cheaper room rates. The State Doubles is again Pocatello on July 12th and probably the 13th. Bob Zausch will again direct the State Doubles. Thanks go out to Bob for his continuing commitment to Idaho State Doubles Tournament.

If you plan to participate in either the State Singles or State Doubles tournaments, your dues must be current. In addition, for Singles, you must have pitched in two tournaments since and including last year's State Singles tournament; for Doubles, you

must have pitched in one tournament since and including last year's State Doubles tournament.

The NHPA has recently announced that beginning in January 2015, *Newsline* will become *eNewsline*, the print magazine will be moving to electronic only, FREE to ALL members of the NHPA, as a benefit of membership. The newsletter will be sent directly to your email inbox and will also be available on the NHPA website.

Get out there and practice, warm weather is coming fast, I hope.

Jerry D. Smith, Secretary-Treasurer
2850 S. Benecia Way
Nampa, ID 83686
horseshoepitcherjds@msn.com



Regional Director Message And Idaho Hall of Fame Report



By this early in the year and what appears to be Springtime, I have received the patches and certificates for all sanctioned tournaments which have been mailed to the appropriate individuals who are tournament directors.

On the Regional Director side of things, I am going to give my yearly reminder about the sanctioning of courts. I once again ask all tournament directors and others associated with the different site locations to again please measure your pegs for distance at the ground level from the front of each peg to the opposing peg and ensure the distance is forty (40') feet and that the peg height is at a minimum of 14 inches and no higher than 15 inches from level ground level per NHPA specs. The angle should also be 3 inches at the base (ground level). As tournament directors we all

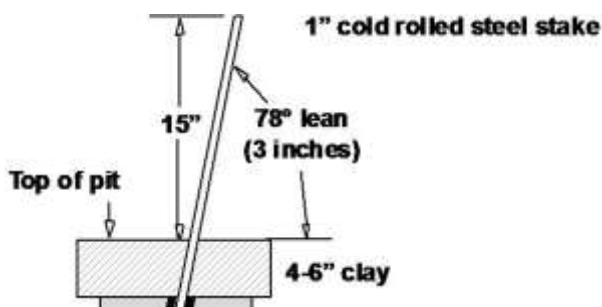

should try and check the pegs at the beginning of a new season so when tournaments roll around, the courts will be in proper playing conditions for all those who travel the many miles to pitch with us.

Wearing my other hat as Chairman of the Hall of Fame, at the state singles tournament to be held in Coeur d'Alene in August, this year two (and possibly three) past ISHPA members will be inducted into the Hall of Fame. The two people are James Kosterman in the "Organizer/Promoter" category and Clarence Cummins in the "Pitcher" category. If a third can be determined, he/she will be announced in the summer newsletter.

To the entire membership, I as your Hall of Fame Chairperson am looking for **FUTURE** candidates for the HOF. The requirements must follow the HOF bylaws in either of the categories as listed on our website. I currently have a list of who I feel are deserving individuals for this honor in horseshoes and the ISHPA.

Good Pitchen,

Dave Spears
Idaho Regional Director
Idaho HOF Chairperson



Newsletter News



My task as newsletter editor is to ensure that the three issues of "Four Dead" that are published each year bring you interesting ISHPA news in a timely manner.

The "timely" part isn't usually much of a problem, but the "interesting" part is more difficult. We publish two versions of each issue of the newsletter: one on paper that is snail-mailed to those for whom we do not have e-mail addresses, and a second one that includes color photos and graphics that is sent by e-mail in PDF format to those with e-mail addresses, as well as posted on the ISHPA web site.

To save on printing and postage costs, the paper version is printed in B&W and limited to a total of four sheets of paper (for a one ounce mailing). But the e-version is in color and can be as long as it

takes to include photos of the horseshoe pitching events that occur around the state.

I ask those of you with cameras who attend or participate in the Idaho tournaments to please take photos of the group winners. Then send me the photos along with the names of the people in the photo so that the photos can be included in the newsletter along with the results of the tournament. You may snail mail me actual photos, which I will scan and then return to you. But it's easier to e-mail me the digital image file.

Photos of your local club events are also welcomed, as is information about your club, when and where it meets, and so on.

Photos can add a lot to a newsletter, but the newsletter also needs articles. If you'd like to write an article about some aspect of horseshoe pitching, please contact me. This newsletter reaches new pitchers as well as those who have pitched for many years/decades.

I am pleased to be able to contribute to the ISHPA as the newsletter editor. We owe so much to Jerry Smith for his many years of editing and publishing "Four Dead." I rely on Jerry to assist me with content, review and correction of drafts, and timing of the issues.

Kay Keskinen, Newsletter Editor
ringergal@yahoo.com



The Use of Hand Signals for Scoring Horseshoe Pitching

by Kay Keskinen

There has been discussion lately about using hand signals to indicate the score in a horseshoe game. The Nov/Dec 2013 issue of *Newsline* included an article by NHPA 1st VP Dan Sanders about hand signals, and there have been postings in the online NHPA Forum under the topic of "New Hand Signals." In addition, on the NHPA web site is a PDF document entitled "Use of Hand Signals for Cancellation Play."

First, what are the ten possible scores that can be called during a game?

1. One Point
2. Two Points
3. One Ringer, Three Points
4. One Ringer, Four Points
5. Two Ringers, Six Points
6. Two Dead, No Score
7. Two Dead, One Point
8. Two Dead, Three Points
9. Four Dead
10. No Score

Why use hand signals for these scores?

Some of the purposes mentioned are these:

- 1) To help ensure that calls are more fully understood by scorekeepers,
- 2) To be used in venues where it is more difficult to be heard,
- 3) To be used when score keepers may have hearing problems, and
- 4) To be used when scorekeepers ask for them.

When I am pitching in a tournament, I try to be considerate of the nearby pitchers, especially those on adjacent courts. Most of us do not step out to pitch while an adjacent pitcher is preparing to pitch, but many yell out the score without considering that the noise may affect the concentration of nearby pitchers. I learned sign language because I had a relative who was deaf, so I have tried to use some of my own hand gestures to the scorekeeper as not to distract others, especially when I am at the distant pit.

The following chart indicates the suggested hand signals for the ten possible scores listed above (from Page 10 of the Nov/Dec 2013 *Newsline* article by Dan Sanders).



USE OF HAND SIGNALS FOR CANCELLATION PLAY





Recommended Hand Signals (as seen by the scorekeeper)

 One Point	 Two Points	 One Ringer, Three Points	 One Ringer, Four Points	 OR 	 No Score	 OR  Signal for 'Dead'	
							
Two Dead, No Score			Two Dead, One Point		Two Dead, Three Points		Four Dead

Note that there are two recommended ways of signaling “dead.” (See chart at the right for alternative method) I join others who prefer the fingers pointing down to signal “dead;” I think it might be easier for the scorekeeper to see. Plus, in the upper chart it takes two hand motions to signal “dead;” there’s a possibility that the scorekeeper might not notice for “Four Dead” the closed fist and count the score as “One Ringer, Four Points.”

These hand signals are recommended by the NHPA to be included in the Guidelines section of the RGS (Rules, Guidelines, and Specifications) Book and other printed information, for distribution to all members. The hand signals will be voted on by the NHPA delegates in 2015.

Recommended Hand Signals (as seen by the scorekeeper)

Two Dead, No Score

Two Dead, One Point

Two Dead, Three Points



**Play Horseshoes for
Fun and Health**

**It's a Family sport
for ALL ages**



horseshoepitching.com

Check it out.

Schedule for 2014

Date	Place	Name	Contact	Sign-in
Mar. 29	Pocatello	WT Qualifier #1	Rim Rock Steve 221-8935	10:00
April 5	Pocatello	WT Qualifier #2	Rim Rock Steve 221-8935	10:00
April 12	Pocatello	WT Qualifier #3	Chalk Horse Juan 221-4564	10:00
April 12	Nampa	Spring Fling #6	Jerry 467-2524	9:30
April 19	Pocatello	WT Qualifier #4	Rim Rock Steve 221-8935	10:00
April 26	Meridian	WT Qualifier	Bob 860-6772	10:00
April 26	Pocatello	Warm-up for the World	Brian 237-3459	10:00
May 3	Pocatello	WT Qualifier #5	Chalk Horse Juan 221-4564	10:00
May 4	Boise	Bill Travis Memorial #11	David 695-8362	9:30
May 10	Pocatello	WT Qualifier #6	Chalk Horse Juan 221-4564	10:00
May 17	Coeur d'Alene	North Idaho Jamboree	Glen 691-0784	8:30
May 17	Meridian	Meridian Parks & Recs #2	Shari 922-4768	9:30
May 24	Nampa	Kollmann Open	Gary 466-8096	9:30
May 31	Pocatello	Rim Rock Flop	Steve 221-8935	10:00
June 7	Nampa	Nampa Classic #3	Jerry 467-2524	8:30
June 14	Meridian	Meridian Open #2	Pep 949-8098	8:30
June 14	Pocatello	Juneteenth/Utah Invit.	Jim 232-8007	10:00
June 21	Coeur d'Alene	Elmer Currie Classic	Glen 691-0784	8:30
June 22	Boise	NHPF Benefit #6	David 695-8362	8:30
June 28	Hailey	Wood River Open	Brent 404-4354	10:00
July 5	Meridian	Don Titcomb Memorial	Jerry 678-2524	8:30
July 12	Pocatello	Idaho State Doubles	Bob 233-2358	10:00
July 14-26		Buffalo, NY	World NHPA 262-835-9108	
Aug. 9	Coeur d'Alene	Inland Empire Memorial	Glen 691-0784	8:30
Aug. 9	Pocatello	10th Portneuf Valley Shootout	Larry 589-9681	10:00
Aug. 9	Nampa	NHPA Benefit #5	Gary 466-8096	8:30
Aug. 16	Meridian	Senior Games (50 and older)	Pep 949-8098	8:30
Aug. 23/24	Coeur d'Alene	Idaho State Championships	Brian 237-3459	8:30
Sept 20	Nampa	Parks & Recs. #4	Jerry 467-2524	9:30
Sept 27	Meridian	Autumn Classic	Pep 949-8098	9:30
Oct. 5	Boise	Fall Roundup #6	David 695-8362	9:30
Oct. 11	Meridian	Pumpkin Shootout\$\$ #3	Pep 949-8098	9:30
Oct. 18	Nampa	8th Last Chance	Gary 466-8096	9:30
Nov. 1	Meridian	Freeze Out Special #4	Bob 860-6772	10:30

Nampa tournaments are at Lakeview Park. Meridian Tournaments are in Settlers Park. Boise tournaments are in Julia Davis Park. All Nampa, Boise, and Meridian entry fees are \$2.00 except Benefits (\$10.00) & Senior Games (\$20.00).

Most Pocatello tournaments are \$20.00 including lunch. Northern tournaments have \$15.00 entry fees and include lunch. State Singles and World are pre-registered. State costs \$20.00, World \$125.00. Pocatello summer leagues are on Tuesday and Thursdays, Contact Jim for Info @ 221-4245. Meridian league is on Tuesday nights, No fee, Contact Floyd @ 871-6856. Boise league is on Monday nights, \$2.00, Contact David @ 695-8362. Nampa league is on Thursday nights, No fee, Contact Gary @ 466-8096. Leagues start in mid-April, check weather.

Idaho Horseshoe Pitcher's Association

Brian Poole, President
2660 S. Fairway Dr.
Pocatello, ID 83201
208-237-3459
bjpoole3564@gmail.com



Glen Wessel, 1st VP
10626 E. Raven Ridge Rd.
Coeur d'Alene, ID 83814
208-691-0784
gwessele10@peoplepc.com



Brent Wood, 2nd VP
Box 646
Hailey, ID 83333
208-404-4354



Jerry D. Smith, Sec./Treas.
State Statistician
2850 S. Benecia Way
Nampa, ID 83686
208-467-2524
horseshoepitcherjds@msn.com



Kay Keskinen, Newsletter
Editor
PO Box 8584
Moscow, ID 83843
ringergal@yahoo.com



David Spears, Regional
Director
2250 S. Columbus
Boise, ID 83705
208-695-8362
ringerguy@gmail.com



Horseshoe Pitching: The ultimate family sport.

Get out and pitch. Get involved.

FOUR DEAD

Official Newsletter of the

IDAHO HORSESHOE PITCHER'S ASSOC.

Jerry D. Smith, Sec./Treas. 208-467-2524

2850 S. Benecia Way

Nampa, ID 83686

horseshoepitcherjds@msn.com